

velleman-**kit** HIGH-Q 

DIGITAL RPM METER K2625

- For two and four stroke petrol engines.
- Range : 100 to 9900 rpm
- Displays hundreds and thousands of rpm (x100 rpm).
- PVC frontplate included.
- Contact debouncing circuit.
- Easy calibration.
- Power supply : 10 to 15VDC/200mA.

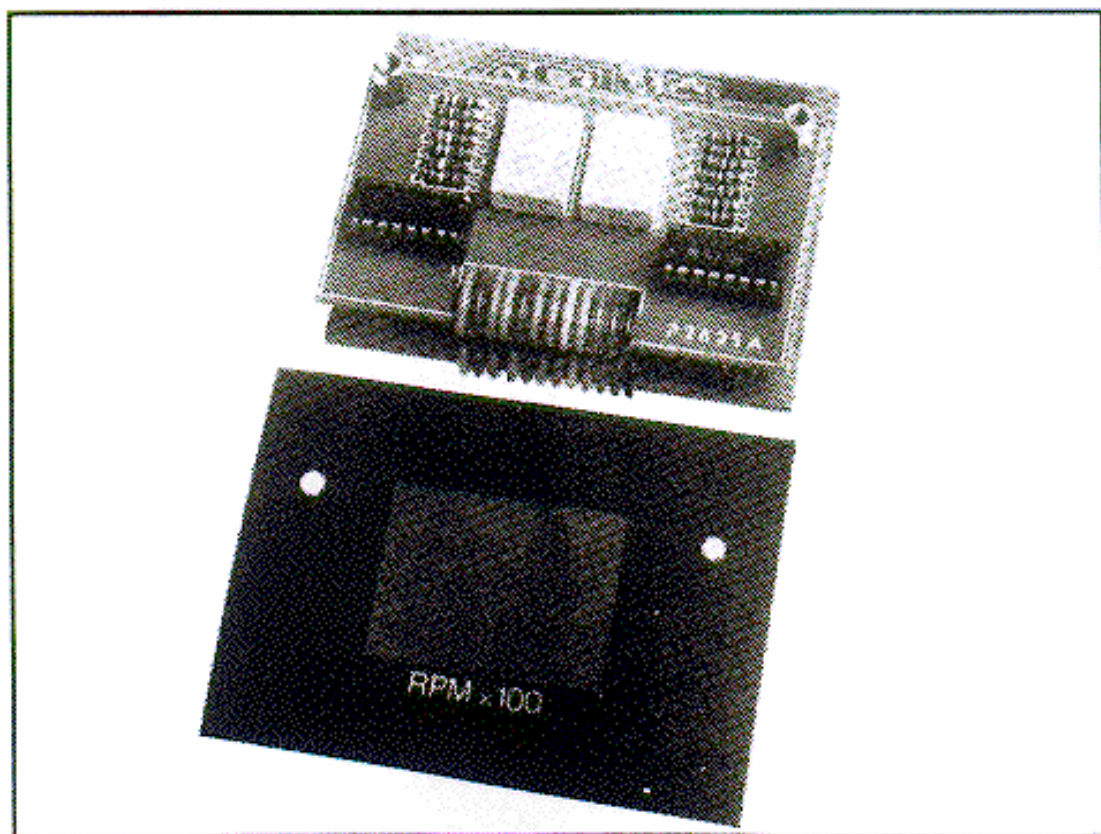

H2625-1

DIGITAL TACHOMETER

This tachometer may be adapted to any car or motorcycle equipped with a petrol engine, whatsoever the number of cylinders.

The kit differs somewhat from the conventional tachometers. Here, the analogic hand is replaced by two displays, giving, in figures, the number of r.p.m. (revolution per minute).

Some advantages are :

- easy reading
- small sized
- no reading error
- robustness

The displays give the hundreds and the thousands of all measured value. The intermediate values are of no interest because the real numbers of r.p.m. are unstable. Furthermore, the unit allows to measure the number of revolutions or the number of movements per minute of any rotating or moving mechanical part.

Only one simple and single setting is needed to calibrate the circuit, giving fully linear scale.

A second trimmer allows to adjust the displays brightness. This latter depends on where the unit is fitted or the ambient light level.

The unit is compact and easy to box, and a frontplate is added to the kit.

Technical data :

- Powersupply : 10...15VDC, not stabilized
- Supply current : maximum 200mA
- CMOS technology
- Resolution : 100 r.p.m.
- Scale : 100...9900 r.p.m.
- Displays : 1/2" LEDs (static)
- Voltage stabilizer on the print
- Input sensitivity : minimum 3V ; maximum 20V
- Input impedance : typ 30K
- Simple calibration
- Adjustable brightness
- Contact bounce suppression

Construction :

The kit uses two separate printed circuit boards, namely :

- the displayprint P2625A
- the baseprint P2625B

First to be constructed is the displayprint. Then the base print.

Displayprint :

- Mount resistors R12 (7 in total), 390 Ohm (orange-white-brown)
- Mount resistors R13 (7 in total), 390 Ohm (orange-white-brown)
- Mount a 16 pin IC socket where marked IC5 and IC6
- Mount both displays. Make sure that the decimal point is located as marked on the board layout. Thus, point downwards near IC5 and IC6
- Mount IC5 and IC6, both of the CD4511 type, or equivalent. Check for the correct position of the notch.
- Remove three wires from one of the flat cables.

Now, mount the flat cables in the 12 holes inside the rectangle. Later on they will be used to make the connection between the display and the baseprint.

Baseprint :

- Mount four straps J1, J2, J3 and J4
- Mount resistor R1, 15K (brown-green-orange)
- Mount R2, 15K resistor (brown-green-orange)
- Mount R3, 10K resistor (brown-black-orange)
- Mount R4, 100K resistor (brown-black-yellow)
- Mount R5, 100K resistor (brown-black-yellow)
- Mount R6, 10K resistor (brown-black-orange)
- Mount R7, 12K resistor (brown-red-orange)
- Mount R8, 10K resistor (brown-black-orange)
- Mount R9, 3K3 resistor (orange-orange-red)
- Mount R10, 10K resistor (brown-black-orange)
- Mount R11, 10K resistor (brown-black-orange)
- Mount RV1, 100K trimmer
- Mount RV2, 47K trimmer
- Mount D1 and D2, small signal diodes ; type 1N914 or 1N4148. Check for the correct polarity !! Sometimes the 1N4148 type is color coded (large yellow ring, brown, yellow,

grey). In this case the LARGE YELLOW RING has to correspond to the line on the print. If the diode is coded by its number, the black ring has to correspond to the line on the p.c.b.

- Mount ZD1, 20V zenerdiode. Check for the polarity !
- Mount C1...C4, 100nF Sibatit condensers
- Mount C5, 100nF MKM condenser
- Mount C6, 1nF ceramic condenser
- Mount C7, 1nF ceramic condenser
- Mount C8, 100nF Sibatit condenser
- Mount C9, 10nF ceramic condenser
- Mount C10, 10uF electrolytic condenser. Check for the polarity.
- Mount C11, 15nF MKM condenser
- Mount C12, 100nF Sibatit condenser
- Mount VR1, voltage regulator : UA7808, MC7808 or equivalent. This regulator has to be placed with its metal side flush with the board. Start first by fixing it with screw and nut. (nut on the regulator's side).

When this is done, you may solder all three connections.

- Mount a 16 pin IC socket where marked IC1
- Mount a 14 pin IC socket where marked IC2
- Mount a 16 pin IC socket where marked IC3
- Mount a 8 pin IC socket where marked IC4
- Mount T1, BC547, 548, 549, BC237, 238 or 239 transistor
- Mount 3 terminals in the holes "+", "-", and "IN"
- Mount IC1, CD4518 or equivalent type, the notch toward C3
- Mount IC2, CD4093 or equivalent type, the notch toward C4
- Mount IC3, CD4098 or equivalent type, the notch toward R6
- Mount IC4, NE555 or equivalent type , the notch toward R8
- Solder the 12 wires, coming from the displayprint, in the holes of the baseprint (these holes are also inside a rectangle). PAY ATTENTION !! The wire marked "1" on the displayprint has to come in the hole "1" of the baseprint. All the other wires, being parallel to the first one, will come automatically at their place.

Do not connect the boards together, mechanically, for the moment.

Test :

- Recheck, by using the manual, if all components are at the right place, and then connect to the points "+" and "-" a powersupply of 10...15V. The "IN" connection remains still free for the moment.
- The signs "00" must now be displayed, whatsoever the position of trimmer RV2.
- The brightness of the displays can be fully adjusted by trimmer RV1
- Testing and setting the tachometer may be done in two different ways :
 - with a transformer (50 or 60 Hz calibration source)
 - with an audio generator.

In both cases, the setting remains the same.

A specific number of revolutions on the display corresponds to a specific frequency at input "IN".

However, the ratio depends on the type of engine and the number of cylindres. This ratio's are given in table 1.

1. Setting with the transformer :

- You have to use a transformer with a secondary voltage of 3...15V. Current is unimportant.
- Connect the output of this transformer to points "-" and "IN"
- Trim RV2 as per table 1, to obtain the correct value displayed according to a specific type of engine and a specific number of cylinders. As already explained, only the hundreds and the thousands are displayed.

2. Setting with an audio generator :

- In this case you will need a very accurate apparatus which is to be set to exactly 50Hz
- The output signal may be sine or square voltage.
- Connect the generator's output to points "-" and "IN". The signal must be at least 3V.
- Trim RV2 as per table 1, to obtain the correct value displayed according to a specific type of engine and a specific number of cylinders.

Mount both boards together using two screws, two nylon spacers and two bushings with internal thread. See figure 1. Bend both boards with the solderside facing to each other and pass a screw through the fixing hole from the component side of the base board. Put a nylon spacer over the screw and pass the screw through the fixing hole of the displayprint and fix with the bushing. Use two extra screws to fix the unit in a housing.

Usage :

Connecting the unit to the engine is very simple. First, the powersupply is connected to the "+" and the "-", which corresponds to the "+" and the "-", respectively, of the battery.

Keep in mind that the +V supply is to be taken after the ignition switch, so the unit will not be powered when the engine is cut. The "IN" input is connected to the positive of the breaker. This point is easily found, as it is the only connecting point between the breaker and the coil. The condenser, which is also connected at that place, may stay as it is. Thus do not remove or disconnect it. As the engine starts the number of revolutions is displayed.

Note :

On some cars (especially those with an electronic ignition system) the meter may display zero at high speeds. In this case, fit a 10K trimmer parallel to the zener diode (RV3 in the schematic diagram). Adjust the trimmer until the meter works perfectly at all speeds.

Function :

The input voltage (+) is stabilized by voltage regulator VR1, providing 8V. C1 and C2 are HF de-coupling condensers. That 8V tension supplies the complete circuit. The to be counted frequency is applied to input "IN" and goes to the base of T1 via R1 and R2. ZD protects T1 against high input voltages and C12 is a low-pass filter for the input signal. There is square wave at the collector of T1, having the same frequency as the input signal. This square wave is applied to IC2, mounted as a monostable (MMV) to suppress the con-

tact bounce of the input signal. This produces a signal with a fixed pulse width at output 12 of IC2, and this, independent from the frequency and the width of the input.

This signal is then applied to the counting input (9) of IC1, which is a double BCD counter, with the BCD outputs connected to IC5 and IC6.

These latter are BCD to 7 segment decoders and control the displays via the series resistors R12 and R13.

An oscillator, whose frequency is adjusted by means of RV2, is built around IC4. The output of IC4(3) is applied to the input (4) of IC3. This IC contains two monostable multivibrators, coupled together in series. Once IC4 has created a pulse, the first MMV is triggered, giving a very small pulse at output 7 of IC3. This pulse is added to the input 5 of IC5 and IC6. Input 5 is the so-called latch input and, during the presence of the pulse, the value of the BCD information goes through it to the displays. When the pulse has disappeared, the last read information is kept on the displays, independently of the BCD input.

Output 7 of IC3 is also connected to the trigger input (12) of the second MMV, which will be triggered at the moment that the pulse disappeared from output 7. At its turn, the second MMV produces a small pulse at output 10, which is connected to the reset inputs 7 and 15 of IC1. This resets the BCD counter, starting again, from zero, to count all incoming pulses of input "IN". RV2 is trimmed so that IC4 creates a pulse when the content of the counter has the desired value for a known input frequency.

A still free part of IC2 is used to build an oscillator of which the duty cycle is set by RV1. This frequency is applied to inputs 4 of IC5 and IC6, which are the so-called blanking inputs. In this way, the brightness of the displays can be controlled.

TABLE 1

CYL.	50Hz signal		60Hz signal	
	2 T	4 T	2 T	4 T
1	3000	6000	3600	7200
2	1500	3000	1800	3600
3	1000	2000	1200	2400
4	750	1500(*)	900	1800(*)
5	—	1200	—	1440
6	—	1000	—	1200
8	—	750	—	900
10	—	600	—	720
12	—	500	—	600

* = most current type of engine

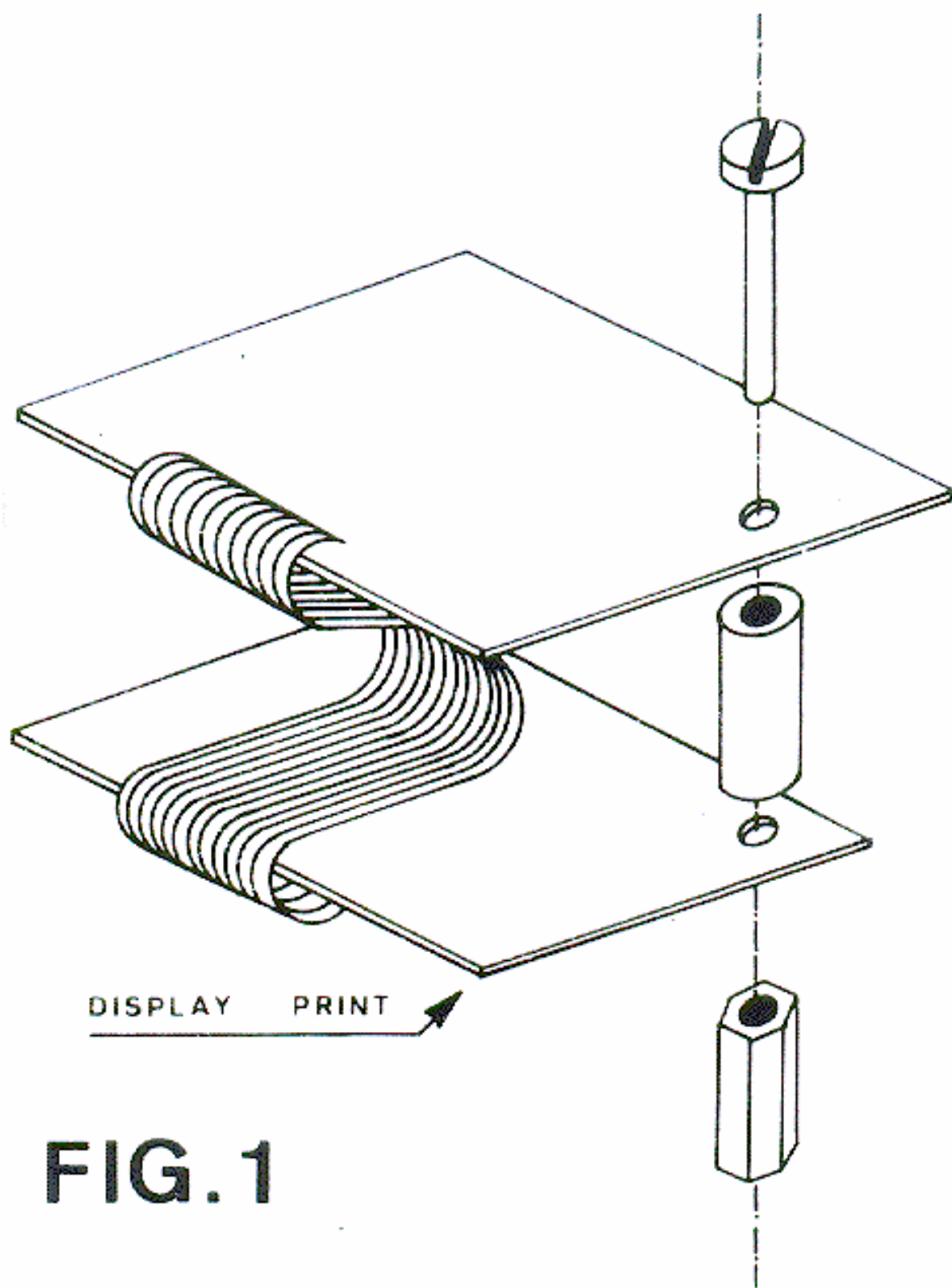

FIG. 1

